

### Features

#### Multi-specification

There are nine specifications: tube I.D.  $\phi$ 20~125. Application to hold state in the stroke range.

#### Brake function

The brake function is bi-directional. It can hold on specific position by sensor switch.

#### Non-lubrication

Designs of oil-filled alloy. Special housing and bushing provide the needed self-lubrication of piston rod.

#### High quality-long service life

Hard anodized aluminum cylinder tubes and stainless steel tubes resist corrosion and abrasion.

#### ISO-VDMA standard specification

Conformance to ISO-6431 & VDMA-24562 specification. Unified design, most parts of each type are interchangeable among each other.

#### Cylinder mountings

Available with a comprehensive selection of mountings for fixed or flexible installation.

### Table for standard stroke

Tube I.D.	Stroke (mm)
$\phi$ 20,25	15,25,50,75,100,125,150,175,200,250,300,350,400,450,500
$\phi$ 32,40	50,75,100,125,150,175,200,250,300,350,400,450,500
$\phi$ 50,63	↑ 600
$\phi$ 80,100,125	↑ 600,700

- Stroke out of specification is also available.
- Please consult us if stroke out of specification.

### Order example

MCBQV2 – 11 – 40 – 100 M

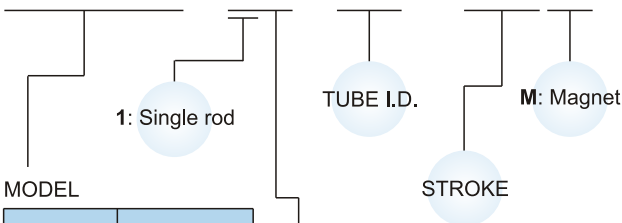

Model	Tube I.D.
MCBMI	$\phi$ 20, $\phi$ 25
MCBQV2	$\phi$ 32~ $\phi$ 100
MCBQI2	$\phi$ 32~ $\phi$ 100
MCBQV	$\phi$ 125

#### STYLE

Code	Symbol	Description
1 1		Double acting / Male thread

### Specification

Model	MCBMI		MCBQI2					
	20	25	32	40	50	63	80	100
Tube I.D. (mm)								
Medium	Air							
Operating pressure range	0.3~0.6 MPa							
Proof pressure	1.5 MPa							
Ambient temperature	-5°C~+60°C (no freezing)							
Min. working pressure	0.3 MPa							
Available speed range	50~500 mm/sec							
Locking mode	Secure locking of piston rod in any position							
Lock retention forces (N)	490	490	790	1240	1930	3060	5400	7700
Sensor switch (※)	RCA, RCM		RCI					
Sensor switch (band)	BA20	BA25	—					
	BM20	BM25	—					

Model	MCBQV2						MCBQV
	32	40	50	63	80	100	125
Tube I.D. (mm)							
Medium	Air						
Operating pressure range	0.3~0.6 MPa						
Proof pressure	1.5 MPa						
Ambient temperature	-5°C~+60°C (no freezing)						
Min. working pressure	0.3 MPa						
Locking mode	Secure locking of piston rod in any position						
Lock retention forces (N)	790	1240	1930	3060	5400	7700	12040
Available speed range	50~500 mm/sec						
Sensor switch (※)	RCA						
Sensor switch (holder)	HV1	HV2	HV3	HV4			

※ RCA, RCM, RCI specification, please refer to page V-05, V-11, V-10.

## ROD LOCKING CYLINDERS

### MCBMI

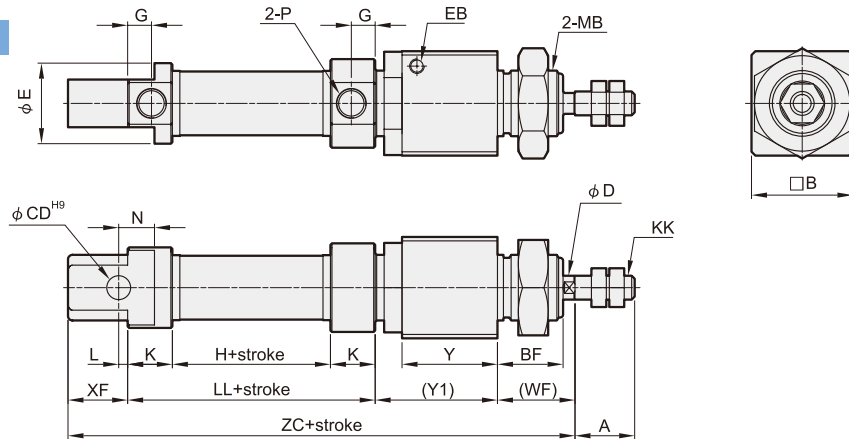

Code Tube I.D.	A	B	BF	CD	D	E	EB	G	H	K	KK	L	LL	MB	N	P	WF	XF	Y	Y1	ZC
20	20	34	22	8	8	27	M5	8	38	15	M8×1.25	3	68	M22×1.5	12	G1/8	26	20	32	43	157
25	22	34	22	8	10	27	M5	7.5	37	15	M10×1.25	9	67	M22×1.5	12	G1/8	28	22	32	45	162

### MCBQV2

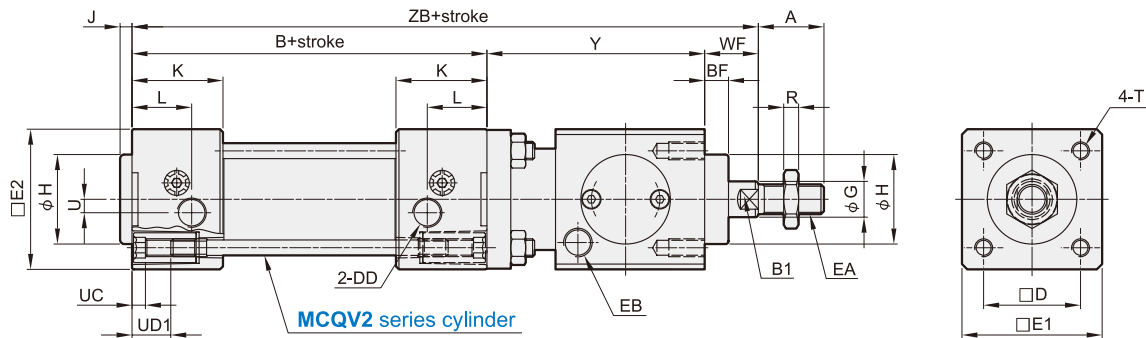

### MCBQI2

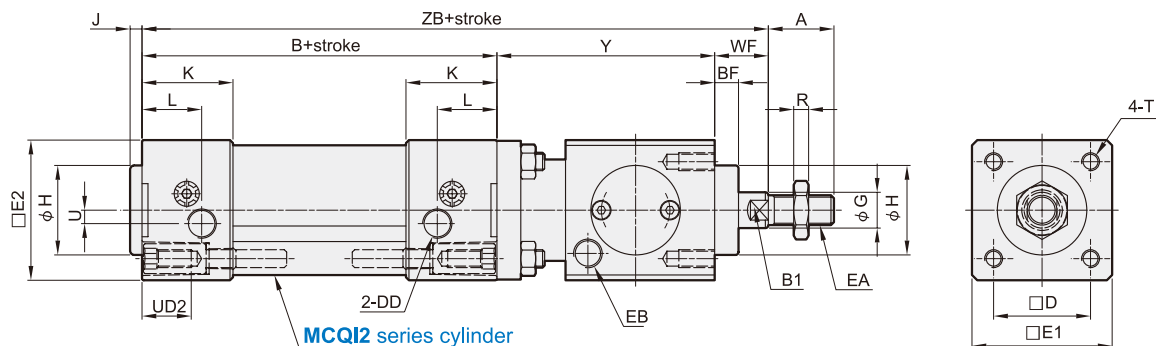

Code Tube I.D.	A	B	BF	B1	D	DD	E1	E2	EA	EB	G	H	J	K	L	R	T	U	UC	UD1	UD2	WF	Y	ZB
32	22	94	7.5	10	32.5	G1/8	47	47	M10×1.25	G1/8	12	30	4	30.5	20	5	M6×12L	4.5	4.5	12	M6×1.0×15L	26	60	180
40	24	105	10	13	38	G1/4	54	53	M12×1.25	G1/8	16	35	4	34	14.5	6	M6×12L	5.3	4.5	12	M6×1.0×15L	30	70	205
50	32	106	10	16	46.5	G1/4	65	65	M16×1.5	G1/8	20	40	4	31	16	8	M8×14L	8.5	4.5	16	M8×1.25×18L	37	90	233
63	32	121	10	16	56.5	G3/8	75	78	M16×1.5	G1/8	20	45	4	33	16	8	M8×14L	8	4.5	16	M8×1.25×18L	37	90	248
80	40	128	10	21	72	G3/8	95	95	M20×1.5	G1/4	25	45	4	35.5	20.5	10	M10×16L	9	4.5	18	M10×1.5×19L	46	110	284
100	40	138	10	21	89	G1/2	114	115	M20×1.5	G1/4	25	55	4	37	19	10	M10×16L	13	4.5	18	M10×1.5×19L	51	110	299

### MCBQV

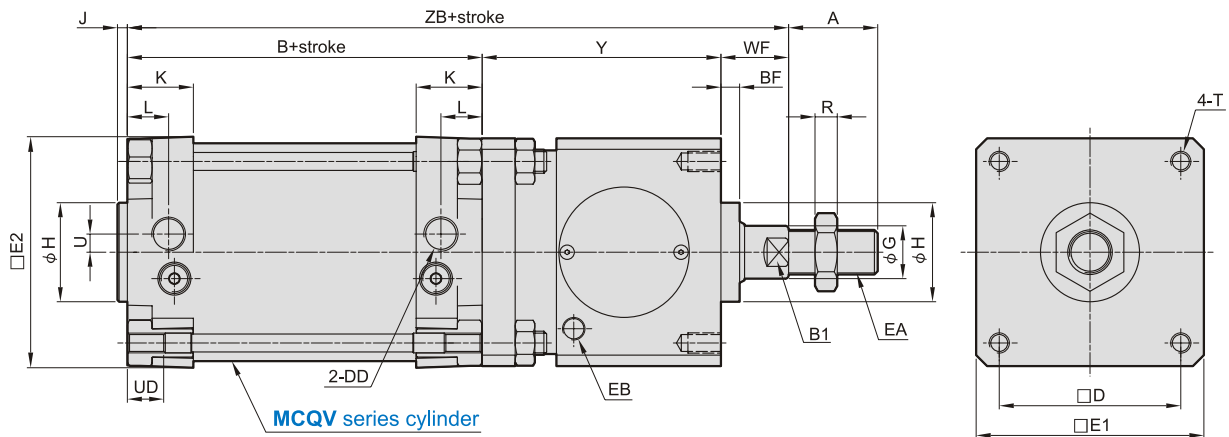

Code Tube I.D.	A	B	BF	B1	D	DD	E1	E2	EA	EB	G	H	J	K	L	R	T	U	UC	UD	WF	Y	ZB
125	54	160	16	27	110	G 1/2	138	140	M27×2.0	G1/4	32	60	6	40	25	13.5	M12×20L	11	22	18	65	140	365