



Table for standard stroke

Tube I.D.	Stroke (mm)
φ 10	25,50,75
φ 16, 20, 25, 32	25,50,75,100,125,150,175,200

Order example

MCDB-03-10-50 M

MODEL

TUBE I.D. STROKE (mm)

TYPE OF BEARING:

03 Slide bearing

M: Magnet

Features

- Compact in width and length with precision guidance.
- High lateral loads can be applied on both slide and linear bearing unit.
- Can be used as body or end plate sliding mechanism.
- Can have shock absorbers fitted enabling absorption of high loads with low noise.

Specification

Model	MCDB		
Acting type	Double acting		
Tube I.D. (mm)	10,16	20	25,32
Port size	M5×0.8		Rc1/8
Medium	Air		
Min operating pressure	0.15 MPa	0.1 MPa	
Max operating pressure	1 MPa		
Proof pressure	1.5 MPa		
Available Temperature range	- 5~+ 60℃ (No freezing)		
Cushion	Shock absorber		
Available speed range	50~500 mm/sec		
Lubricator	Not required		
Stroke adjustable range	Stand stroke ±2mm		
Sensor switch	RCD		

※ RCD specification, please refer to page V-08.

Installation of sensor switch

Sensor switch: RCD

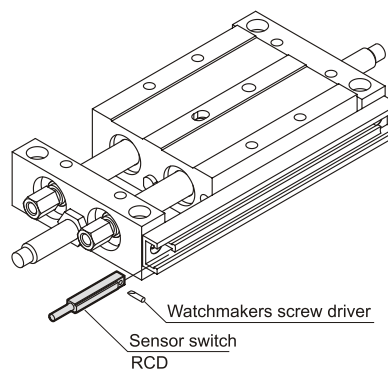
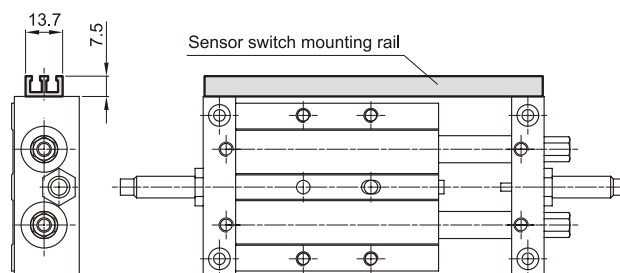

DUAL-ROD SLIDE CYLINDER

$\phi 10$

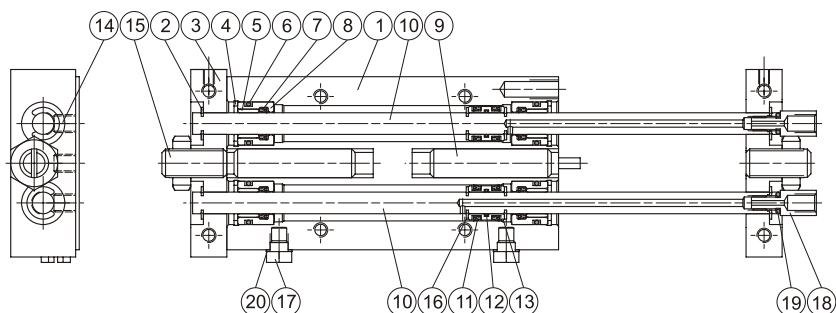

$\phi 16, \phi 25$

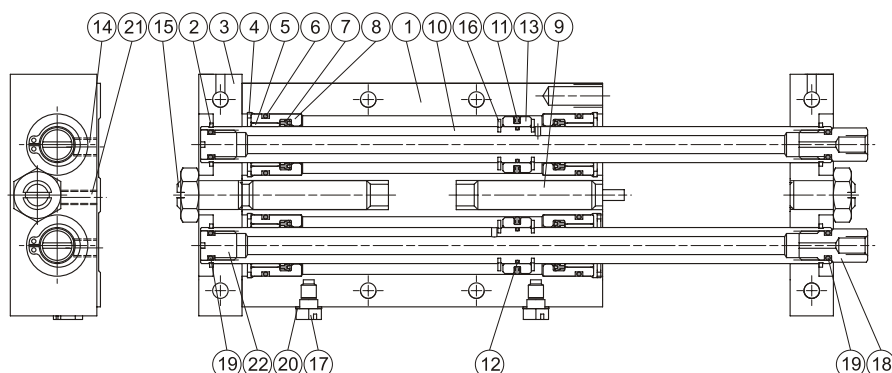

Material:

No.	Part name	Material	Q'y	Repair kits (inclusion)
1	Body	Aluminum alloy	1	
2	Snap ring #1	Spring steel	4	
3	Connector	Aluminum alloy	2	
4	Snap ring #2	Spring steel	4	
5	Rod bush	Bearing alloy	4	
6	Cover gasket	NBR	4	●
7	Rod packing	NBR	4	●
8	Rod cover	Aluminum alloy	4	
9	Absorber	—	2	
10	Piston rod	Carbon steel	2	
11	Piston packing	NBR	2	●
12	Piston gasket	NBR	2	●
13	Piston	Aluminum alloy	2	
14	Set screw #1	Carbon steel	4	
15	Set screw #2	Carbon steel	2	
16	Snap ring #3	Spring steel	4	
17	Plug #1	Copper	2	
18	Fitting	Steel	2	
19	O ring for fitting	NBR	4	●
20	Plug gasket	Plastic	2	
21	Set screw #3	Carbon steel	2	
22	Plug #2	Copper	2	

Order example of repair kits

Tube I.D.	Repair kits
$\phi 10$	PS-MCDB-10
$\phi 16$	PS-MCDB-16
$\phi 25$	PS-MCDB-25

DUAL-ROD SLIDE CYLINDER

$\phi 20, \phi 32$

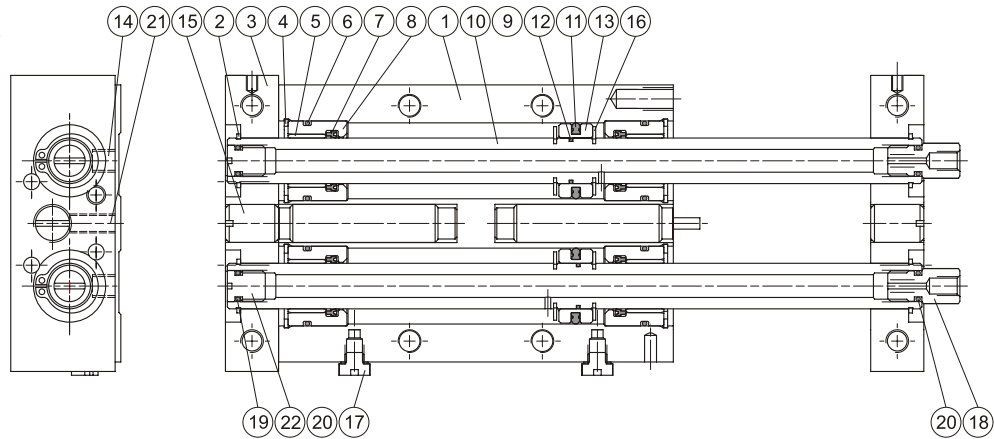

Material

No.	Part name	Material	Q'y	Repair kits (inclusion)
1	Body	Aluminum alloy	1	
2	Snap ring #1	Spring steel	4	
3	Connector	Aluminum alloy	2	
4	Snap ring #2	Spring steel	4	
5	Rod bush	Bearing alloy	4	
6	Cover gasket	NBR	4	●
7	Rod packing	NBR	4	●
8	Rod cover	Aluminum alloy	4	
9	Absorber	—	2	
10	Piston rod	Carbon steel	2	
11	Piston packing	NBR	2	●
12	Piston gasket	NBR	2	●
13	Piston	Aluminum alloy	2	
14	Set screw #1	Carbon steel	4	
15	Set screw #2	Carbon steel	2	
16	Snap ring #3	Spring steel	4	
17	Plug #1	Copper	2	
18	Fitting	Steel	2	
19	O ring for fitting	NBR	4	●
20	Plug gasket	Plastic	2	
21	Set screw #3	Carbon steel	2	
22	Plug #2	Copper	2	

Order example of repair kits

Tube I.D.	Repair kits
$\phi 20$	PS-MCDB-20
$\phi 32$	PS-MCDB-32

MCDB-03 Dimensions $\phi 10, \phi 16, \phi 25$ stroke: 25

DUAL-ROD SLIDE CYLINDER

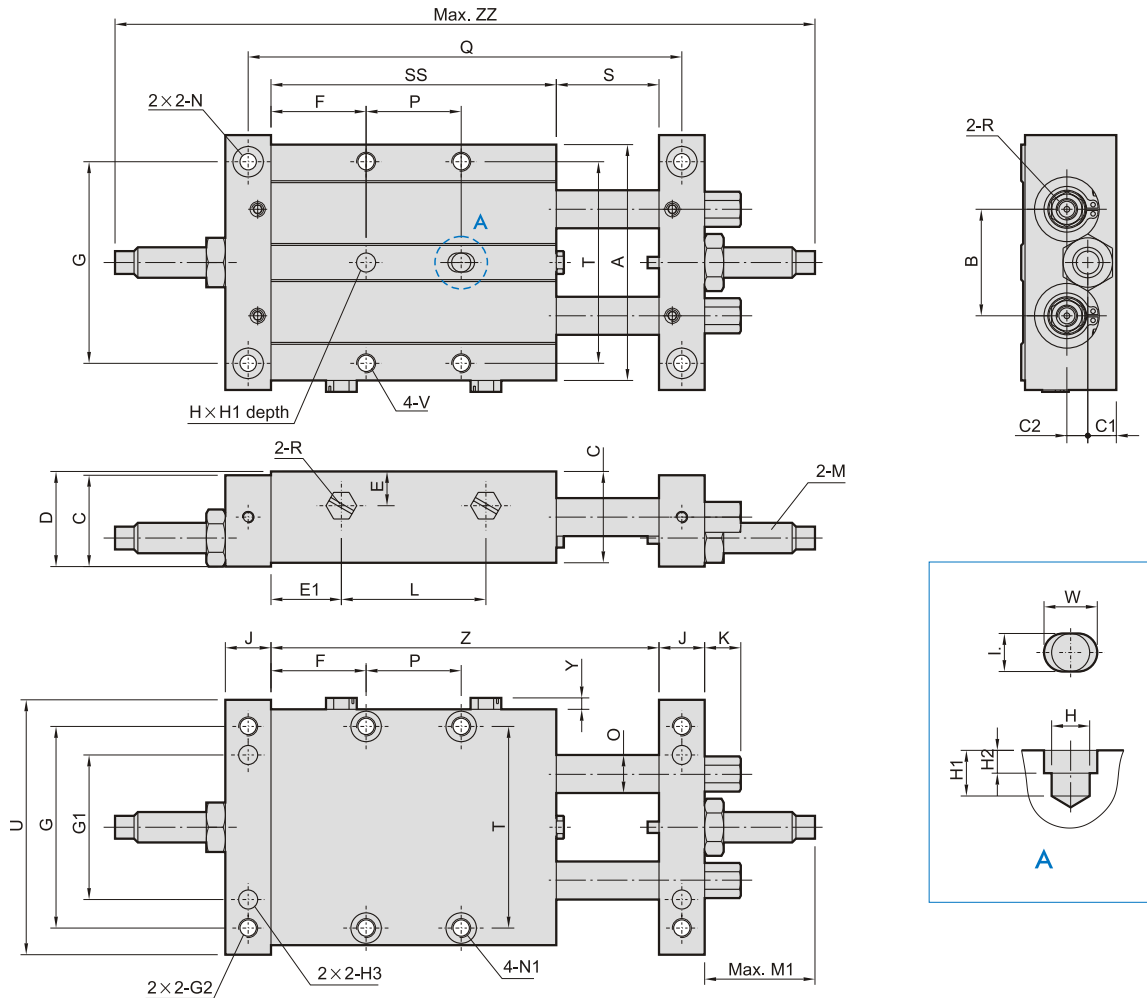

(mm)

Tube I.D.	Code Stroke	A	B	C	C1	C2	D	E	E1	F	G	G1	G2	H _(H7)	H1	H2	H3 _(H7)	I	J	K	L	M
10	25	48	22	18	6.5	2.5	19	6.5	14.5	21	40	28	M4×0.7×8dp	φ4	6	3	φ4×5dp	φ4	10	9.5	38	M8×1.0(MAC-0806-SN)
16	25	62	28	24	7.5	5.5	25	9	18.5	25	53	38	M5×0.8×10dp	φ5	6	3	φ5×6dp	φ5	12	9.5	38	M8×1.0(MAC-0806-SN)
25	25	79	35	32	9	9	34	16	19.5	28.5	67	50	M6×1.0×12dp	φ6	8	4	φ6×8dp	φ6	16	-	43	M10×1.0(MAC-1007-SN)

Tube I.D.	Code Stroke	M1	N	N1	O	P	Q	R	S	SS	T	U	V	W	Y	Z	ZZ
10	25	32.6	φ 3.3thru 6.5×3.2dp	φ 3.2thru 6.5×3.3dp	φ 6	25	104	M5×0.8	27	67	37	52	M4×0.7×6dp	6	3	94	179.2
16	25	30.6	φ 4.3thru 8×4.5dp	φ 4.3thru 8×4.5dp	φ 10	25	114	M5×0.8	27	75	53	67	M5×0.8×10dp	7	3	102	187.2
25	25	33	φ 5.2thru 9.5×5dp	φ 5.5thru 9.5×5.5dp	φ 12	25	125	Rc1/8	27	82	67	84	M6×1.0×12dp	8	-	109	207



MCDB-03 ϕ 10 stroke: 50~75 / ϕ 16, ϕ 25 stroke: 50~200



DUAL-ROD SLIDE CYLINDER

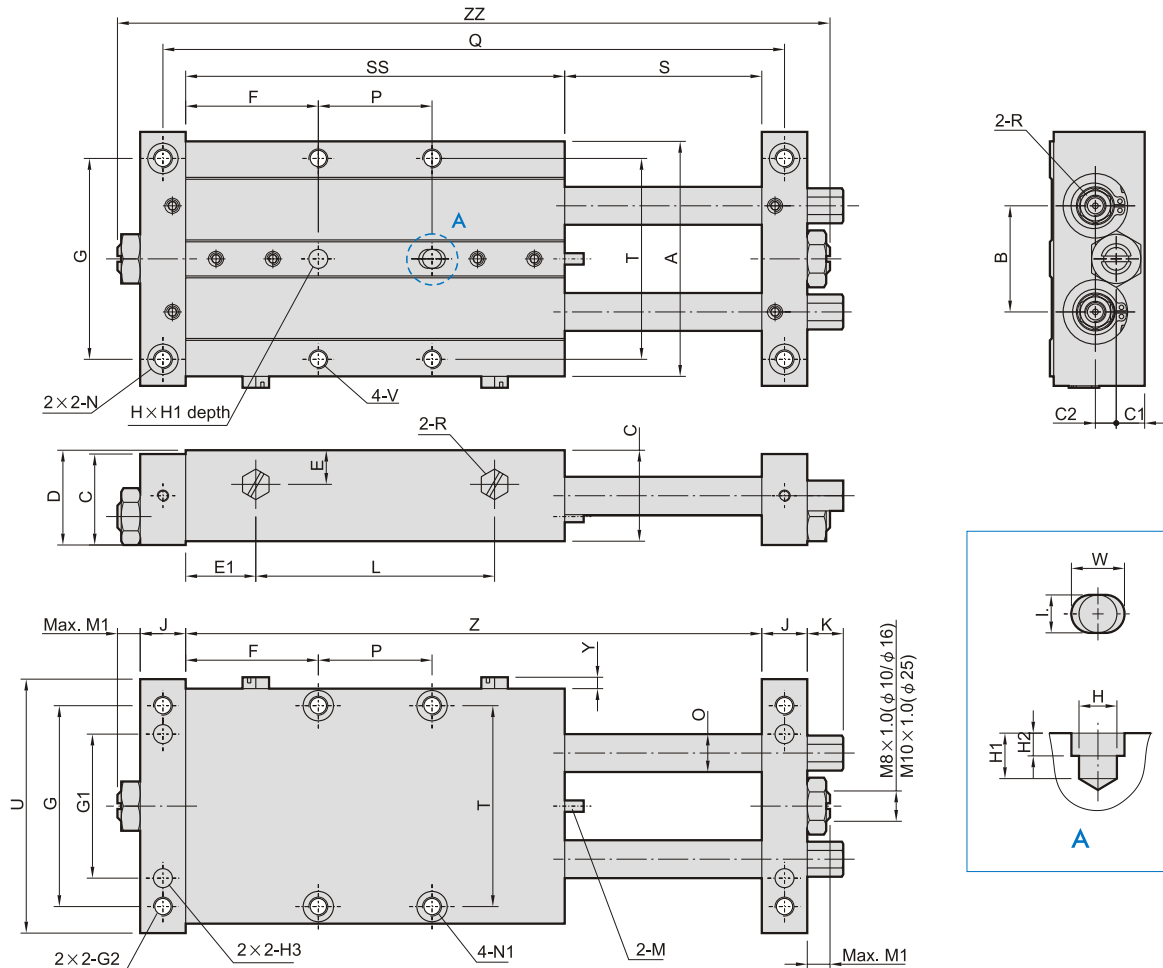

MCDB-03

(mm)

Tube I.D.	Code Stroke	A	B	C	C1	C2	D	E	E1	G	G1	G2	H _(H7)	H1	H2	H3 _(H7)	I	J	K	M	M1
10	50~75	48	22	18	6.5	2.5	19	6.5	14.5	40	28	M4×0.7×8dp	ϕ 4	6	3	ϕ 4×5dp	ϕ 4	10	9.5	M8×1.0(MAC-0806-2)	8
16	50~200	62	28	24	7.5	5.5	25	9	18.5	53	38	M5×0.8×10dp	ϕ 5	6	3	ϕ 5×6dp	ϕ 5	12	9.5	M8×1.0(MAC-0806-2)	6
25	50~200	79	35	32	9	9	34	16	20.5	67	50	M6×1.0×12dp	ϕ 6	8	4	ϕ 6×8dp	ϕ 6	16	-	M10×1.0(MAC-1008-2)	6

Tube I.D.	Code Stroke	N	N1	O	R	T	U	V	W	Y
10	50~75	ϕ 3.3thru 6.5×3.2dp	ϕ 3.2thru 6.5×3.3dp	ϕ 6	M5×0.8	37	52	M4×0.7×6dp	6	3
16	50~200	ϕ 4.3thru 8×4.5dp	ϕ 4.3thru 8×4.5dp	ϕ 10	M5×0.8	53	67	M5×0.8×10dp	7	3
25	50~200	ϕ 5.2thru 9.5×5dp	ϕ 5.5thru 9.5×5.5dp	ϕ 12	Rc1/8	67	84	M6×1.0×12dp	8	-

MCDB-03 : ϕ 10

Code Stroke	F	L	P	Q	S	SS	Z	ZZ
50	26	63	40	154	52	92	144	172
75	26	88	65	204	77	117	194	222

MCDB-03 : ϕ 16

Code Stroke	F	L	P	Q	S	SS	Z	ZZ
50	35	63	30	164	52	100	152	188
75	32.5	88	60	214	77	125	202	238
100	37.5	113	75	264	102	150	252	288
125	42.5	138	90	314	127	175	302	338
150	55	163	90	364	152	200	352	388
175	67.5	188	90	414	177	225	402	438
200	80	213	90	464	202	250	452	488

MCDB-03 : ϕ 25

Code Stroke	F	L	P	Q	S	SS	Z	ZZ
50	31	66	45	175	52	107	159	203
75	33.5	91	65	225	77	132	209	253
100	33.5	116	90	275	102	157	259	303
125	46	141	90	325	127	182	309	353
150	58.5	166	90	375	152	207	359	403
175	71	191	90	425	177	232	409	453
200	83.5	216	90	475	202	257	459	503



MCDB-03 $\phi 20$ stroke: 25 / $\phi 32$ stroke: 25~50



DUAL-ROD SLIDE CYLINDER

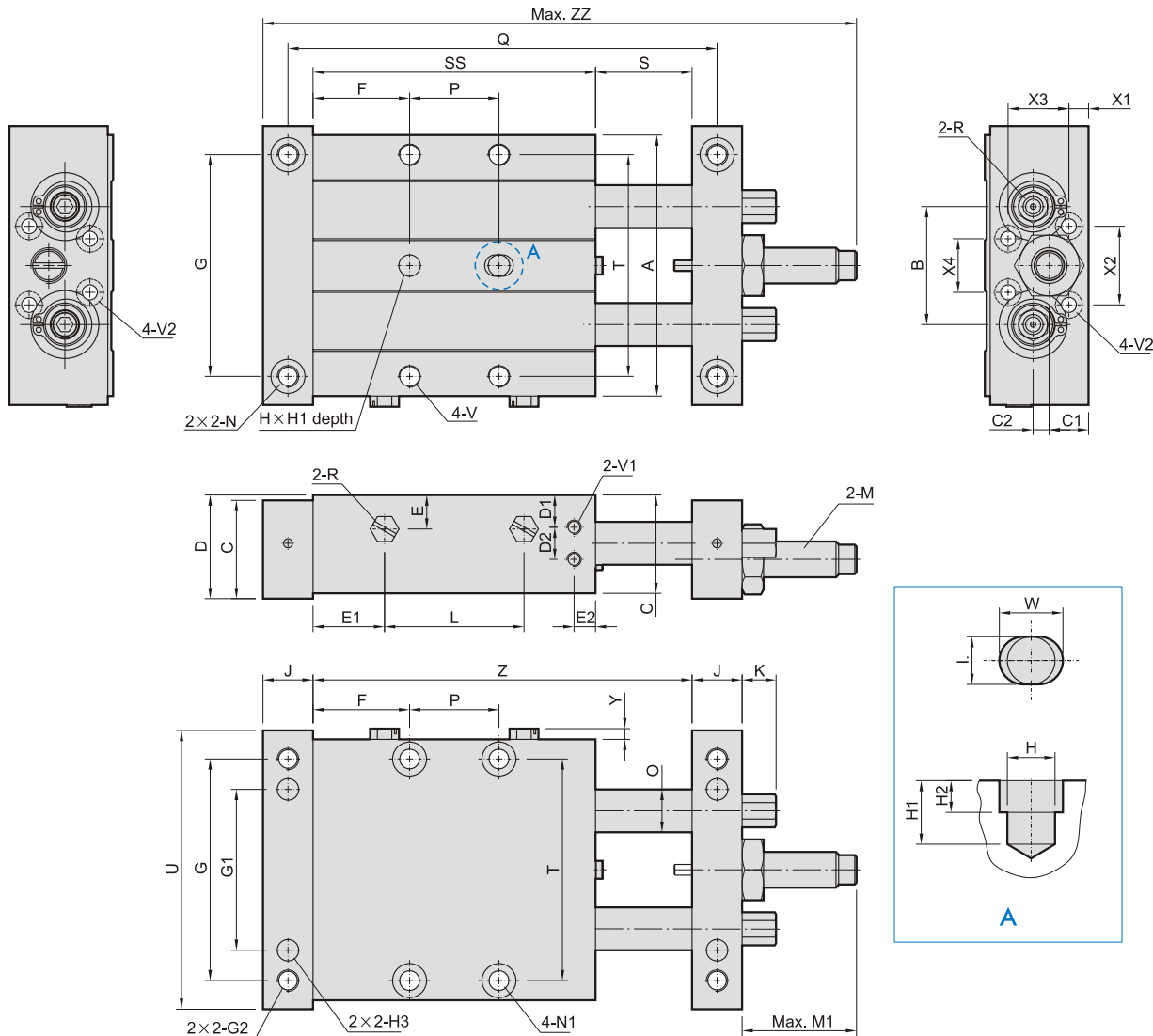

MCDB-03

(mm)

Tube I.D.	Code Stroke	A	B	C	C1	C2	D	D1	D2	E	E1	E2	F	G	G1	G2	H _(H7)	H1	H2	H3 _(H7)	I	J	K	L
20	25	73	33	27.5	11	4.5	29	9	9	9.5	20	6	27	62	45	M6×1.0×12dp	φ6	8	4	φ6×8dp	φ6	14	9.5	39
	50	113	55	38.5	13.5	7	40	10.5	12	15	27.5	10	37	105	84	M8×1.25×15dp	φ8	12	6	φ8×12dp	φ8	20	14.5	41
32	25										28		38											65
	50																							

Tube I.D.	Code Stroke	M	M1	N	N1	O	P	Q	R	S	SS	T	U	V
20	25	M10×1.0(MAC-1008-2)	32	φ5.2thru 9.5×5dp	φ5.5thru 9.5×5.5dp	φ12	25	120	M5×0.8	27	79	62	78	M6×1.0×9dp
	50	M14×1.5(MAC-1412-SN)	50	φ6.9thru 11×6.5dp	φ6.9thru 11×7dp	φ20	22	143	Rc1/8	27	96	100	118	M8×1.25×15dp
32	25						45	193		52	121			
	50													

Tube I.D.	Code Stroke	V1	V2	W	X1	X2	X3	X4	Y	Z	ZZ
20	25	M4×0.7×5dp	M5×0.8thru 7.5×4.5dp(back side)	8	5.5	22	17	15	3	106	166
	50										
32	25	M6×1.0×7dp	M5×0.8thru 7.5×4.5dp(back side)	10	7.5	31	24.5	31	-	123	213
	50									173	263



MCDB-03 $\phi 20$ stroke: 50~200 / $\phi 32$ stroke: 75~200



DUAL-ROD SLIDE CYLINDER

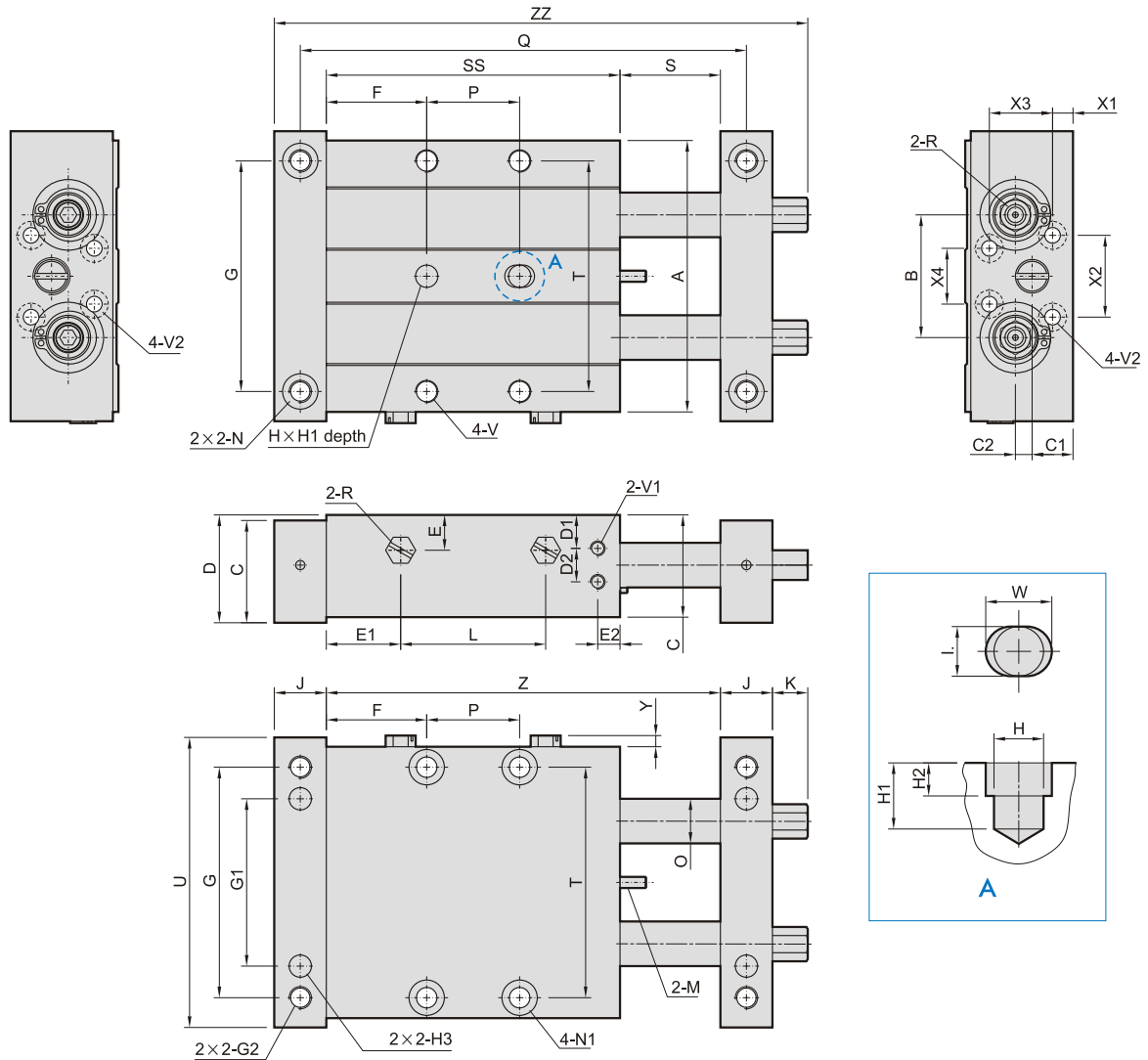

MCDB-03

(mm)

Tube I.D.	Code Stroke	A	B	C	C1	C2	D	D1	D2	E	E1	E2	G	G1	G2	H _(H7)	H1	H2	H3 _(H7)	I	J	K	M
20	50~200	73	33	27.5	11	4.5	29	9	9	9.5	20	6	62	45	M6×1.0×12dp	φ6	8	4	φ6×8dp	φ6	14	9.5	M10×1.0(MAC-1008-2)
32	75~200	113	55	38.5	13.5	7	40	10.5	12	15	28	10	105	84	M8×1.25×15dp	φ8	12	6	φ8×12dp	φ8	20	14.5	M14×1.5(MAC-1412-SN)

Tube I.D.	Code Stroke	N	N1	O	R	R1	T	U	V	V1	V2	W	X1	X2	X3	X4	Y
20	50~200	φ5.2thru 9.5×5dp	φ5.5thru 9.5×5.5dp	φ12	M5×0.8	M4×0.7×5dp	62	78	M6×1.0×9dp	M4×0.7×5dp	M5×0.8thru 7.5×4.5dp(back side)	8	5.5	22	17	15	3
32	75~200	φ6.9thru 11×6.5dp	φ6.9thru 11×7dp	φ20	Rc1/8	M6×1.0×7dp	100	118	M8×1.25×15dp	M6×1.0×7dp	M5×0.8thru 7.5×4.5dp(back side)	10	7.5	31	24.5	31	-

MCDB-03 : $\phi 20$

Code Stroke	F	L	P	Q	S	SS	Z	ZZ
50	34.5	64	35	170	52	104	156	193.5
75	34.5	89	60	220	77	129	206	243.5
100	39.5	114	75	270	102	154	256	293.5
125	44.5	139	90	320	127	179	306	343.5
150	57	164	90	370	152	204	356	393.5
175	69.5	189	90	420	177	229	406	443.5
200	82	214	90	470	202	254	456	493.5

MCDB-03 : $\phi 32$

Code Stroke	F	L	P	Q	S	SS	Z	ZZ
75	38	90	70	243	77	146	223	277.5
100	38	115	95	293	102	171	273	327.5
125	38	140	120	343	127	196	323	377.5
150	38	165	145	393	152	221	373	427.5
175	38	190	170	443	177	246	423	477.5
200	38	215	195	493	202	271	473	527.5

