

MACP300 series

AIR UNITS (F.R.L.UNIT)



mindman



Specification

Model	MACP300	
Components	MAFR300, MAL300	
Bore No.	8A	10A
Port size	1/4	3/8
Medium	Air	
Operating pressure range	0.05~1 MPa	
Proof pressure	1.5 MPa	
Regulated pressure range	0.05~0.85 MPa	
Ambient temperature	-5~+60°C (No freezing)	
Filter element	Standard: 5 μm Option: 40 μm	
Lubricating oil capacity	55c.c	
Min. Flow for oil drip	50 ℓ/min	60 ℓ/min
Recommended lubricating oil	Turbine oil ISO-VG32	
Attachment	Pressure gauge (PG-40), T-type bracket	
Weight	724 g	

Symbol

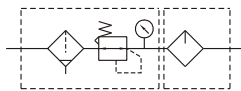

※ Standard unit contains semi-auto-drain function when operating pressure below 0.05 MPa.

Order example

MACP300 - 8A - D - □ - T8 - □

MODEL

BORE SIZE

8A: 1/4
10A: 3/8

FILTER ELEMENT

Blank: 5 μm
40u: 40 μm

Module mounting bracket

T8: 1/4
T10: 3/8

PORT THREAD

Blank: Rc thread
G: G thread
NPT: NPT thread

D: Auto drain valve (MADV300)
N: Nylon bowl

Flow feature

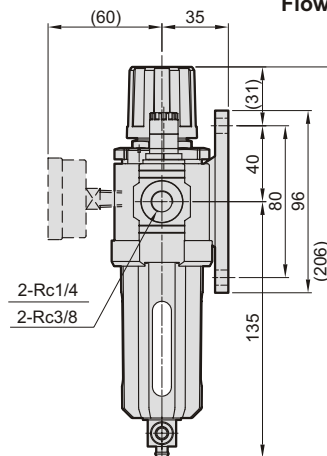
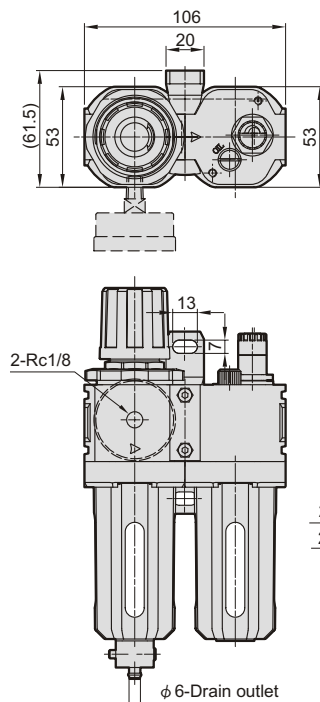
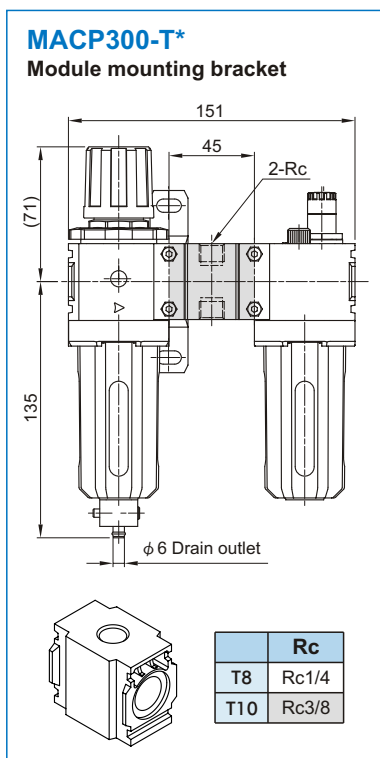
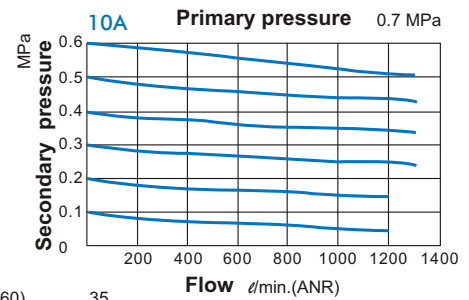
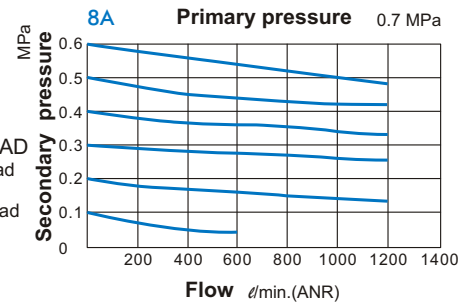

mindman