



### Specification

Model	MSB*	
Medium	Air	
Operating pressure range	0.2~1 MPa	
Proof pressure	1.5 MPa	
Ambient temperature	-5~+60°C (No freezing)	
Lubrication	Not required	
Cushion	With rubber cushion pad	
Sensor switch	RCA for $\phi$ 50	RCB, RCE, RCE1
Sensor switch holder	HS	

※ RCA, RCB specifications please refer to the V-05, V-07 page.

### Order example

**MSBD-32-20-(L-K-L)-G-V-4E2-AC110**

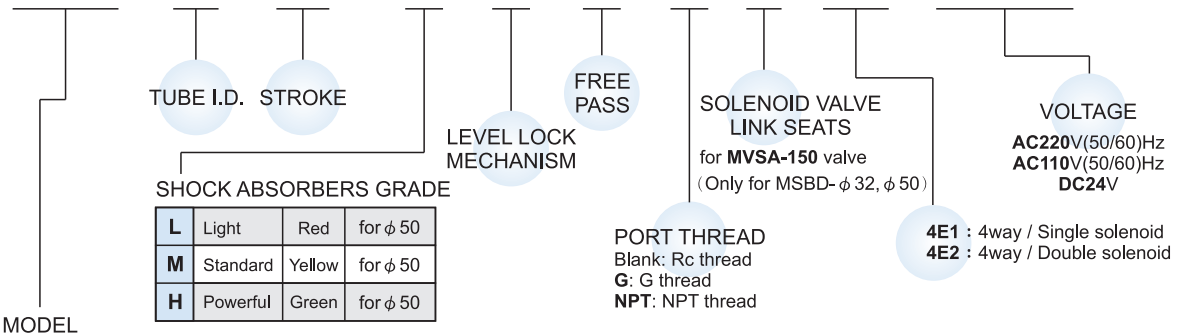

MODEL	Type of cylinder	Operation type	Standard stroke	Magnet	Sensor switch	Weight
<b>MSBD</b>		Shockless stopper (Double acting with spring)	$\phi$ 32-20	○	RCE, RCE1	740 g
			$\phi$ 50-30	○	RCA	1800 g
			$\phi$ 63-30	○	RCB, RCE, RCE1	3680 g
			$\phi$ 80-40	○		6820 g

**MSBR-40-30-G**

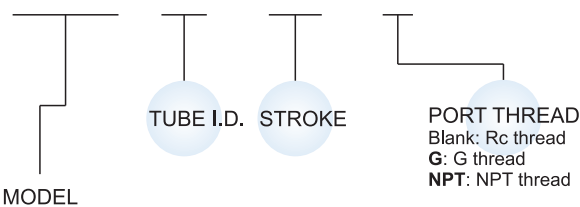

MODEL	Type of cylinder	Operation type	Standard stroke	Magnet	Sensor switch	Weight
<b>MSBR</b>		Stopper with roller (Double acting)	$\phi$ 20-20	○	RCB	250 g
			$\phi$ 32-20	○	RCE, RCE1	740 g
		Stopper with roller (Single acting-Spring extended)	$\phi$ 40-30	×	—	1400 g
			$\phi$ 50-30	×	—	1800 g
<b>MSBS</b>		Direct stopper (Double acting)	$\phi$ 20-10	○	RCB	192 g
			$\phi$ 32-20	○	RCE, RCE1	720 g
			$\phi$ 50-30	○	RCA	1850 g

### Piping diagram

Single acting

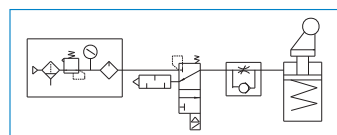

Double acting

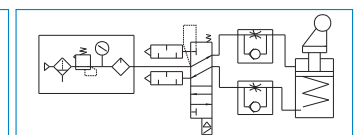

## Pallet control stopper type

### Shock absorber built-in

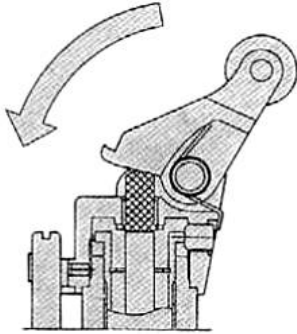

Absorbs the shock when the carried object stops, and stops the object softly on the right Position. There is an adapter between the lever and shock absorber, which straightens the inclined load on the lever and transmits it to the lever.

### Lever lock mechanism

With this optional feature, the carried object is not pushed back by the lever. Also the Object returns to the right position after being lifted up. The lock is released by supplying air and lowering the rod.

### Stopper mechanism

Guide bar equipped for fixing the direction of the roller lever.

### Light aluminum

Main cylinder part, shock absorber, and roller lever are integrated in the aluminum die cast body. The best cylinder for the light and space-saving conveyor line.

### Free pass mechanism

Setting the pass-plate on the lever holder, the lever is fixed in the OFF position. Use the optional feature when the carried object needs to pass over the cylinder.



### Solenoid valve and sensor switch

Magnet-sensing sensor switch is available for MS\*\* Reed or "solid state" switches with LED is fixed, not need to adjust the position, 3-way and 4-way solenoid Valve can be directly mounted on the cylinder.

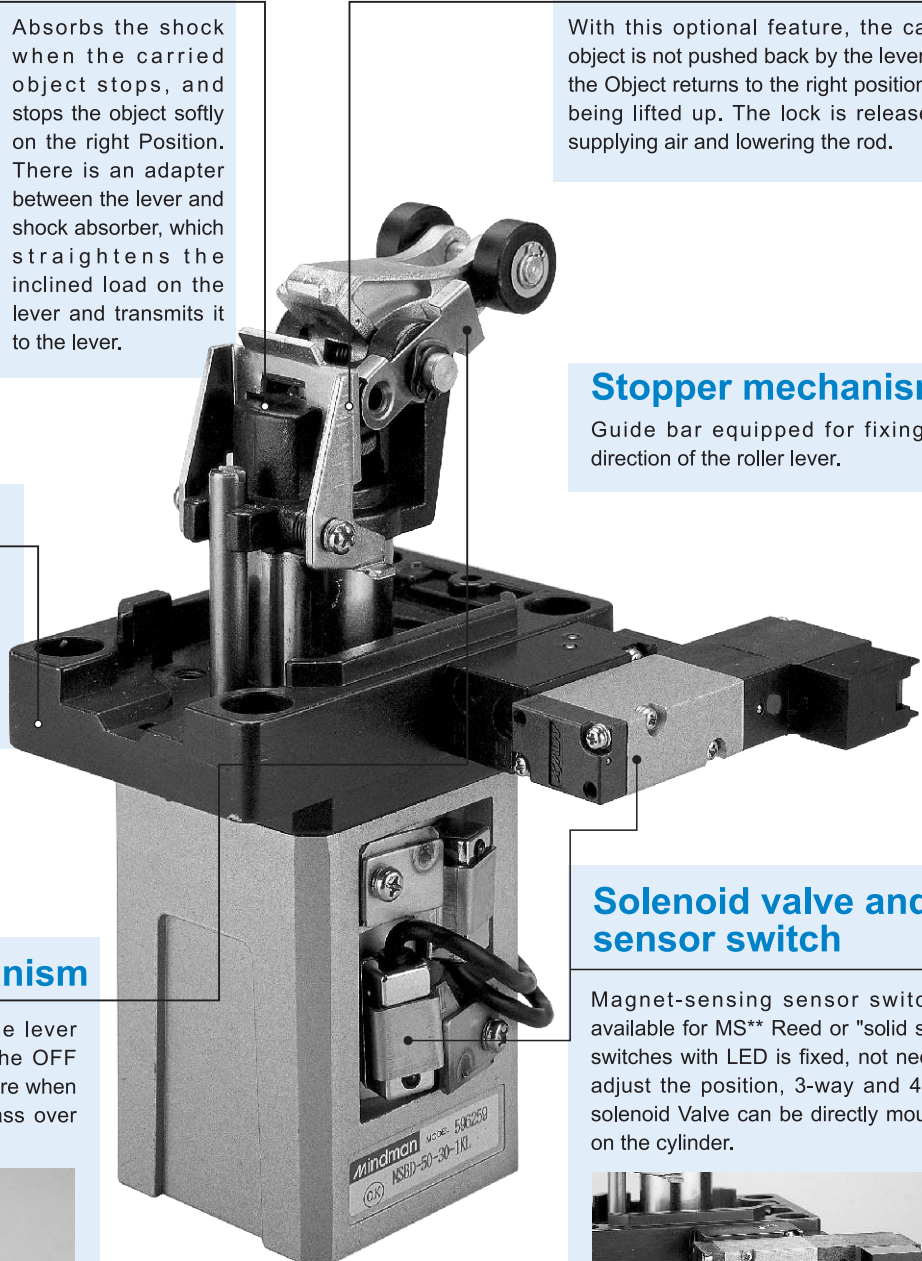
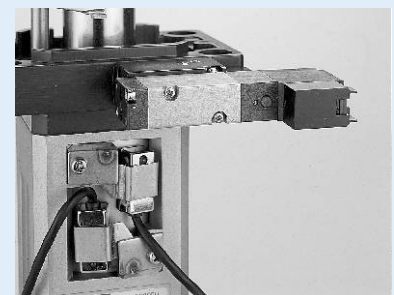

### MSBD $\phi 32-20$

#### Capacity

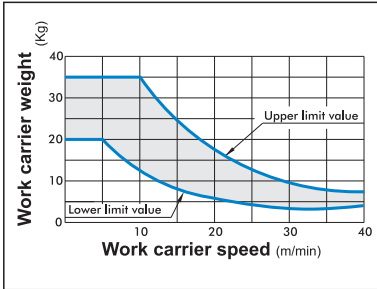

### MSBD $\phi 32-20, \phi 50-30$

#### Normal lateral load

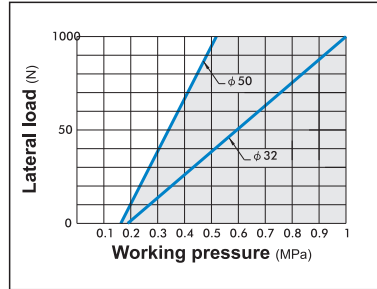

### MSBD $\phi 50-30$

#### Capacity Light weight type

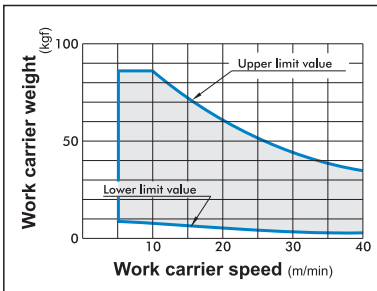

#### Capacity Standard type

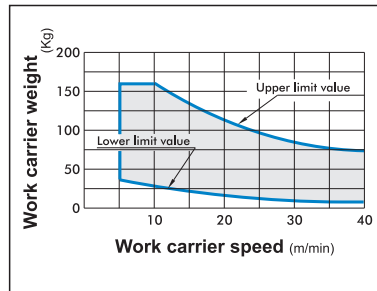

#### Capacity Heavy duty type

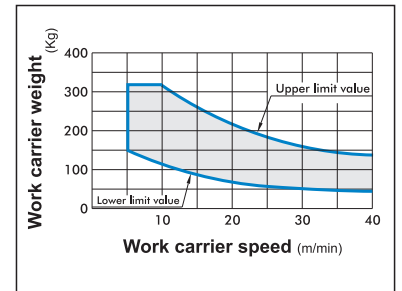

### MSBD $\phi 63-30, \phi 80-40$

#### Capacity

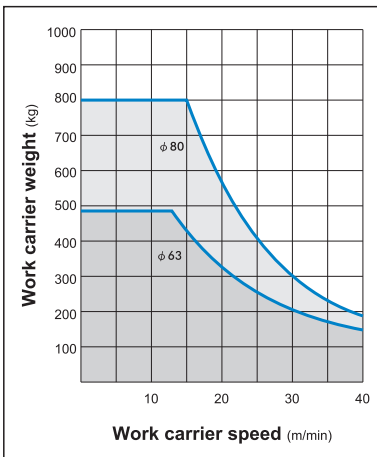

#### Normal lateral load

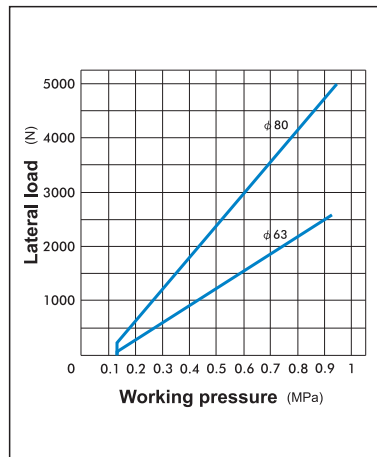

### MSBD $\phi 32-20$

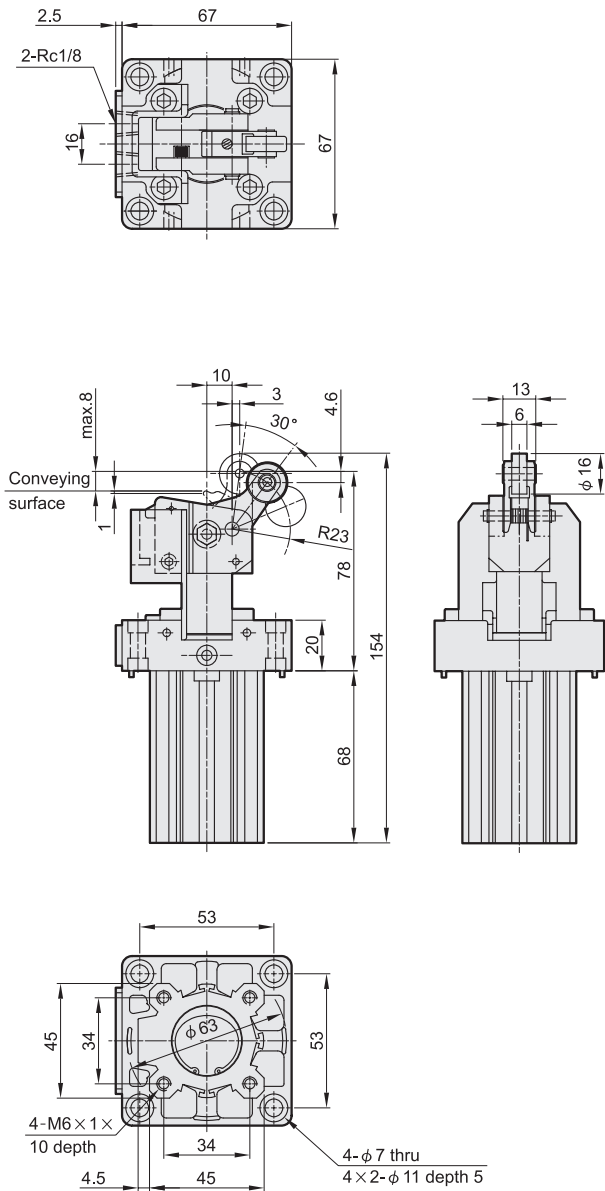

### MSBD $\phi 32-20-V$

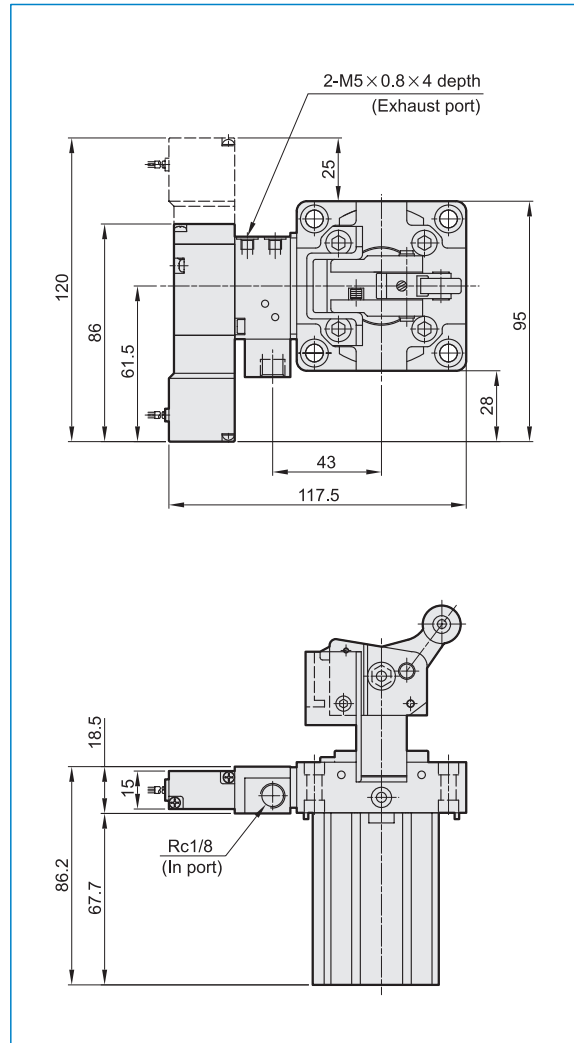

### MSBD $\phi 50-30$

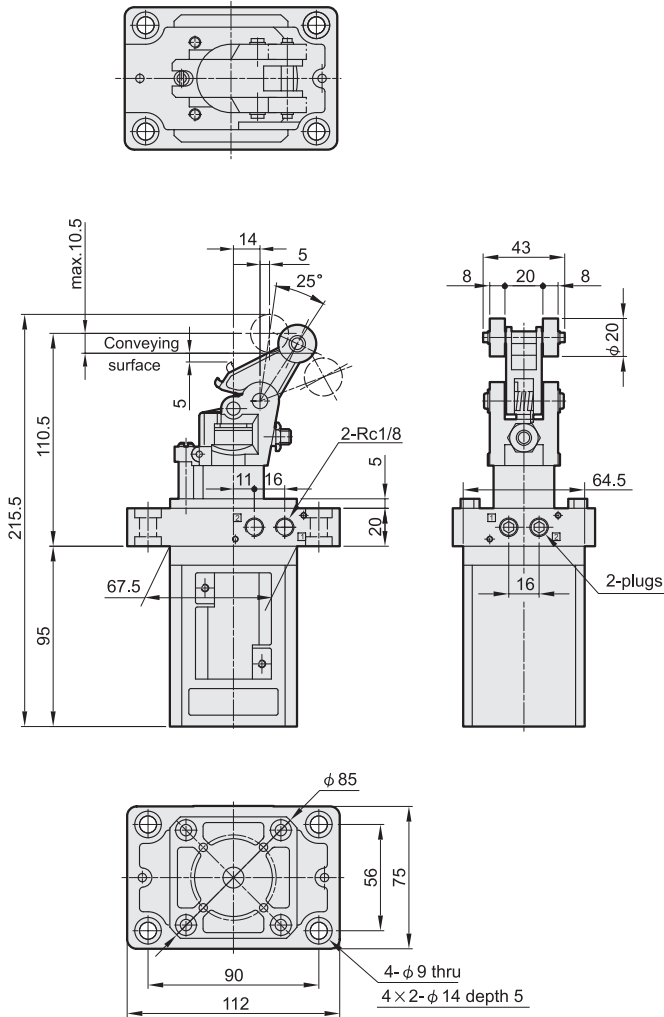

### MSBD $\phi 50-30-V$

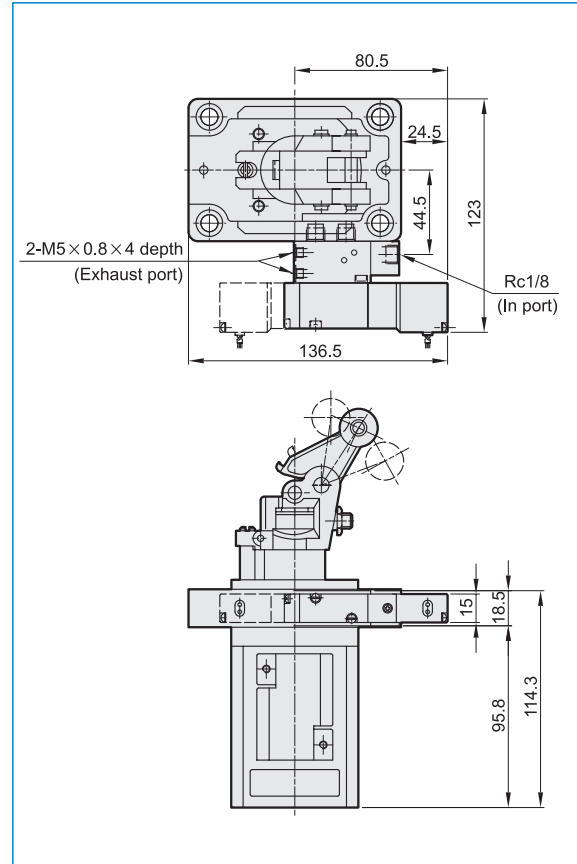

### Option accessories

**MSBD- $\phi 50 \times 30-K$**   
Lever lock mechanism

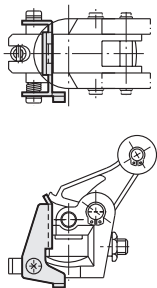

**MSBD- $\phi 50 \times 30-L$**   
Free pass mechanism

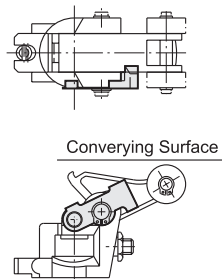

Conveying Surface

## STOPPER CYLINDER

MSBD  $\phi 63-30$

MSBD  $\phi 80-40$

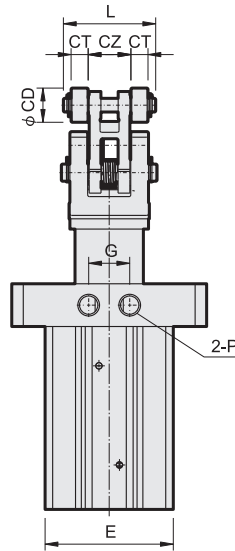
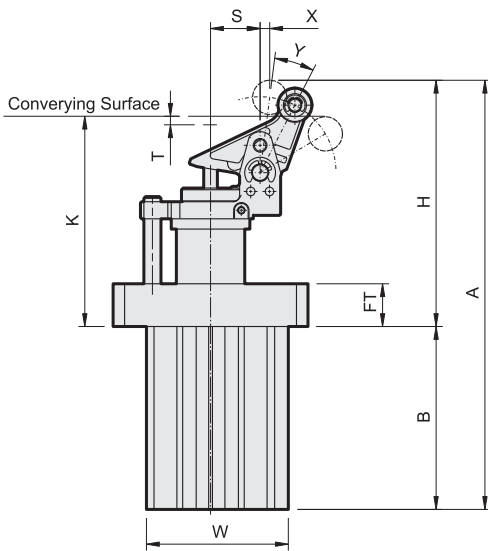
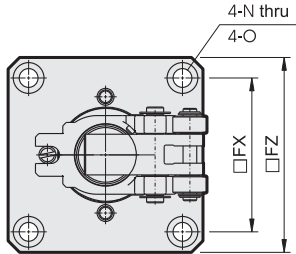

### Option accessories

MSBD- $\phi 63-30-K$   
MSBD- $\phi 80-40-K$

Lever lock mechanism

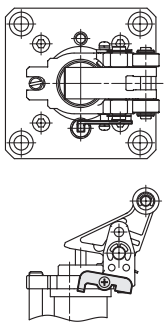

MSBD- $\phi 63-30-L$   
MSBD- $\phi 80-40-L$

Free pass mechanism

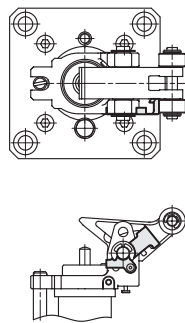

Tube I.D.	Stroke	A	B	CD	CT	CZ	E	FT	FX	FZ	G	H	K	L	N	O	P	S	T	W	X	Y
63	30	251	107	20	10	25	75	25	90	114	24	144	123	54	$\phi 11$	18 x 6 depth	Rc1/4	29	5	83	6	20°
80	40	322.5	145	25	12	30	94	25	110	140	24	177.5	150	63	$\phi 13$	20 x 6 depth	Rc1/4	36	4	102	8	22°

**MSBR**  
Capacity

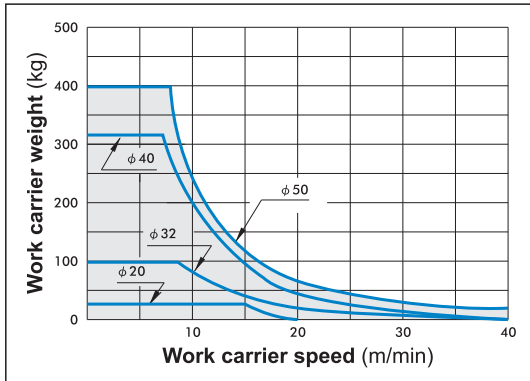

**MSBR**  
Normal lateral load

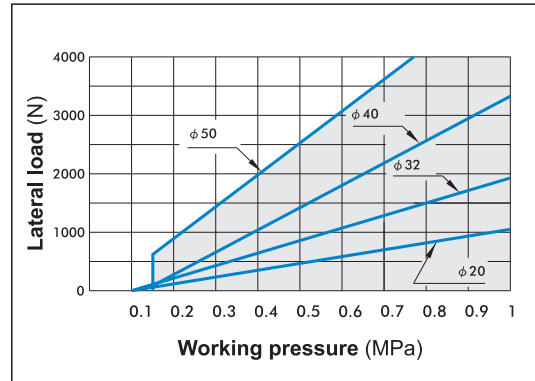

**MSBS**  
Capacity

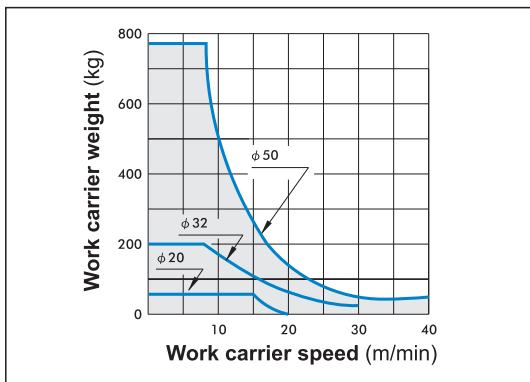

**MSBS**  
Normal lateral load

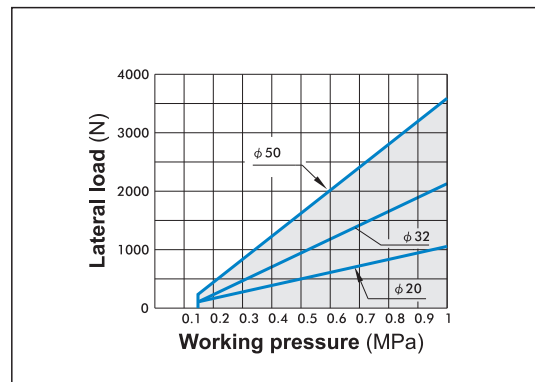

## STOPPER CYLINDER

### MSBR $\phi 20-20$

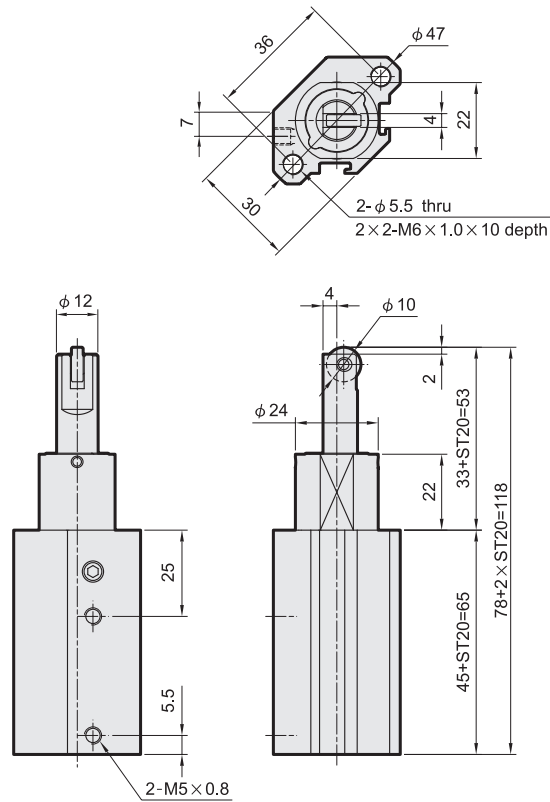

### MSBR $\phi 32-20$

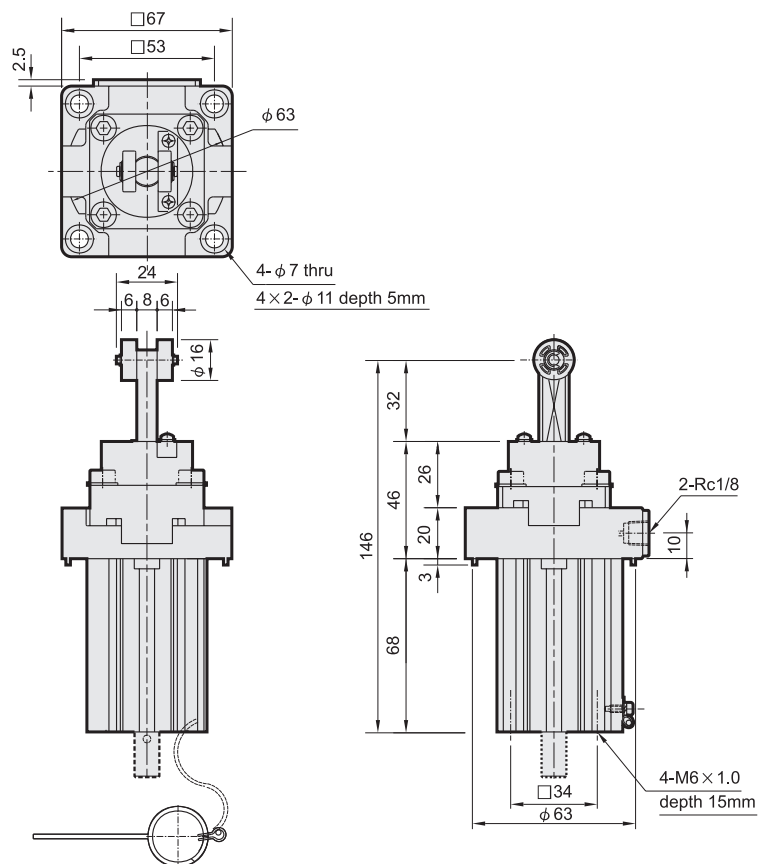



### MSBR $\phi 40$ -30

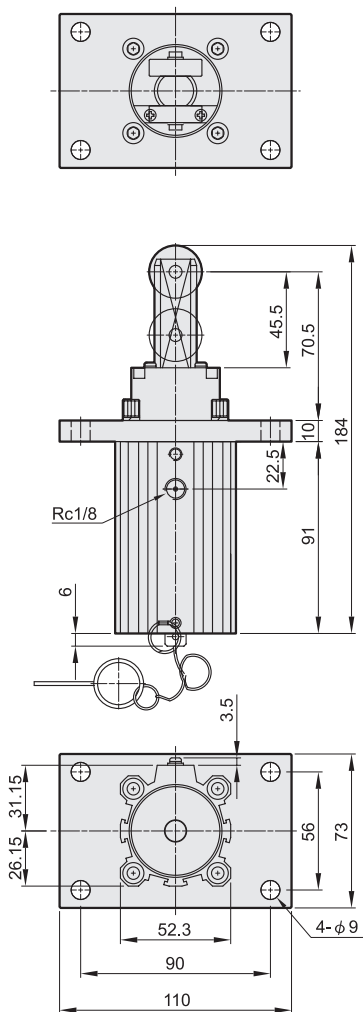

### MSBR $\phi 50$ -30

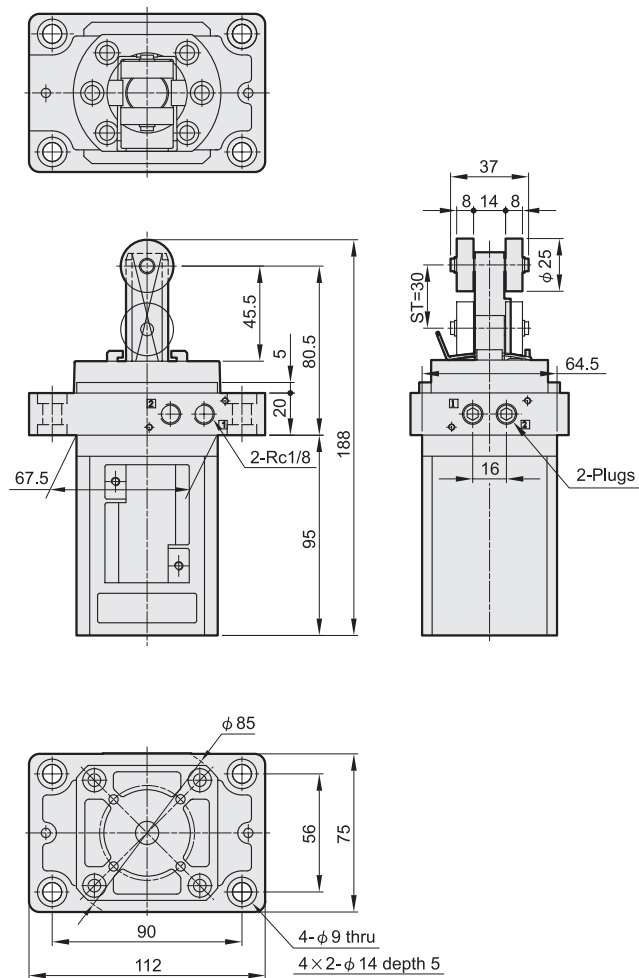

**STOPPER CYLINDER**

**MSBS  $\phi 20-10$**

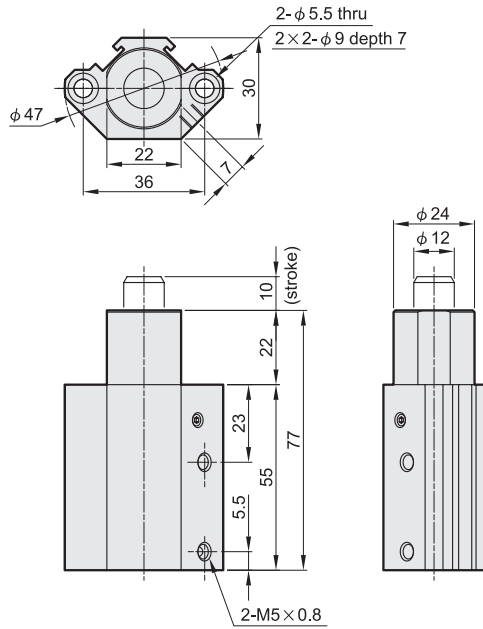

**MSBS  $\phi 32-20$**

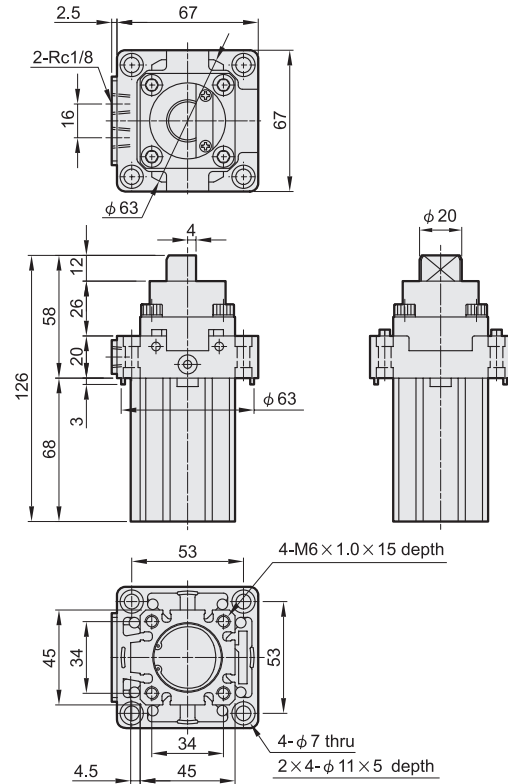

**MSBS  $\phi 50-30$**

