



### Features

- 50 % space saving.
- Magnetic transit design. Magnetic force transits the movement with piston side magnet and silder magnet.
- Stainless tube, light weighted and durable.
- All series are without switch types.

### Specification

Model	MCRPM			
Acting type	Double acting			
Tube I.D. (mm)	20	25	32	40
Port size	Rc1/8		Rc1/4	
Medium	Air			
Max. operating pressure	0.7 MPa			
Min. operating pressure	0.18 MPa			
Proof pressure	1 MPa			
Ambient temperature	+5°C ~ +60°C			
Lubricator	Without lubrication			
Available speed range	100~500 mm/sec			
Holding force (N)	231	363	588	922

### Table for standard stroke

Tube I.D.	Stroke (mm)	Max. stroke	
		Pad	Air
φ 20	100, 150, 200, 250, 300,	1500	1000
φ 25	350, 400, 450, 500, 600,	2000	1000
φ 32, 40	700, 800	2000	900

※: Minimum stroke unit 1mm.

### Order example

MCRPM-20-100-A-G

MODEL

TUBE I.D.

STROKE

PORT THREAD  
Blank: Rc thread  
G: G thread  
NPT: NPT thread

Blank: With cushion pad  
A: With adjustable cushion

### Cylinder weight

unit:g

Model	Basic weight MCRPM	Stroke 100 mm MCRPM
Tube I.D.		
φ 20	413	43
φ 25	657	46
φ 32	1,177	66
φ 40	1,996	83

### Dimensions

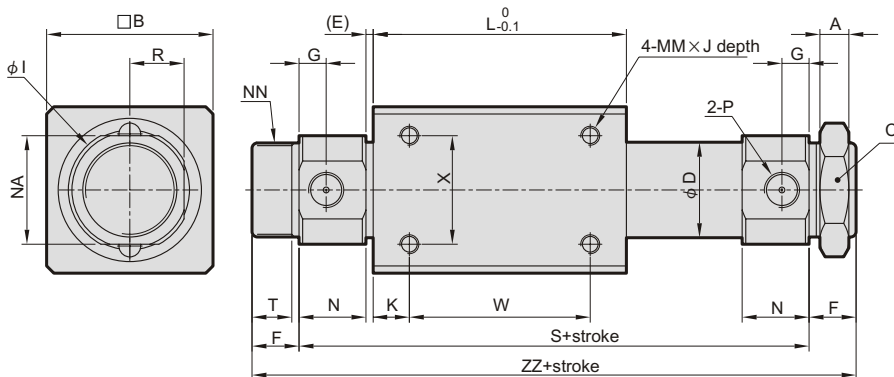

Code Tube I.D.	A	B	C	D	E	F	G	I	J	K	L	MM	N	NA	NN	R	S	T	W	X	ZZ	P
20	8	36	26	21.6	2	13	7.5	28	6	8	66	M4×0.7	18	24	M20×1.5	12	106	10.5	50	25	132	Rc1/8
25	8	46	32	26.4	2	13	7.5	34	8	10	70	M5×0.8	18.5	30	M26×1.5	15	111	10.5	50	30	137	Rc1/8
32	8	60	32	33.6	2	16	8	40	8	15	80	M6×1.0	20	36	M26×1.5	18	124	14	50	40	156	Rc1/8
40	10	70	41	41.6	3	16	11	50	10	16	92	M6×1.0	26	46	M32×2.0	23	150	13	60	40	182	Rc1/4

### Cushion pad type

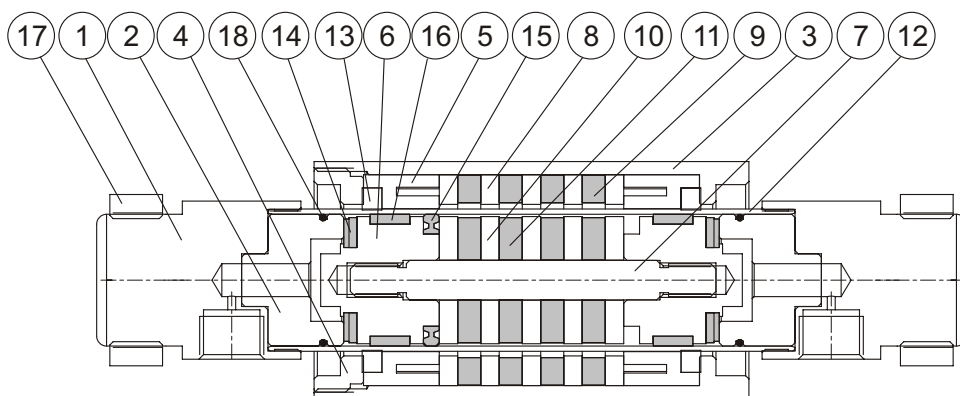

### Cushion air type

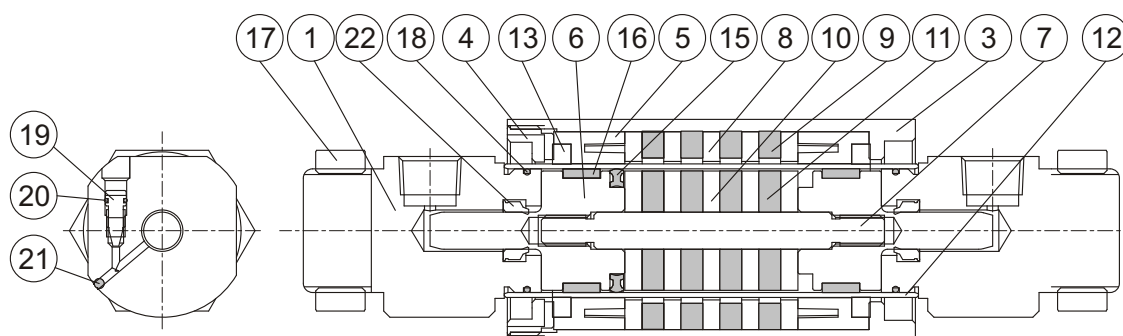

### Material

No.	Cushion		Part name	Material	Note
	Air	Pad			
1	●	●	Cover	Aluminum alloy	Anodized
2		●	End collar	Aluminum alloy	
3	●	●	Slider body	Aluminum alloy	Anodized
4	●	●	Body cover	Aluminum alloy	Anodized
5	●	●	Body wear ring	POM	
6	●	●	Piston	Aluminum alloy	
7	●	●	Shaft	Stainless steel	
8	●	●	Slider side yoke	Carbon steel	Ni plated
9	●	●	Slider side magnet	Magnet material	Ni plated
10	●	●	Piston side yoke	Carbon steel	Ni plated
11	●	●	Piston side magnet	Magnet material	Ni plated

No.	Cushion		Part name	Material	Note
	Air	Pad			
12	●	●	Tube	Stainless steel	
13	●	●	Lubretainer	Special resin	
14		●	Cushion	NBR	
15	●	●	Piston seal	NBR	
16	●	●	Wear ring	POM	
17	●	●	Cover nut	Carbon steel	Ni plated
18	●	●	O ring	NBR	
19	●		Needle valve	Carbon steel	
20	●		O ring	NBR	
21	●		Steel ball	Stainless steel	
22	●		Cushion	NBR	