

MAF401 series

AIR UNITS (Filter)



Mindman

Specification

Model	MAF401		
Bore No.	8A	10A	15A
Port size	1/4	3/8	1/2
Medium	Air		
Operating pressure range (※1.2.)	0.05~1.5 MPa		
Proof pressure	2 MPa		
Ambient temperature	-5~+60°C (No freezing)		
Filter element	Standard: 40 μm Option: 5 μm		
Max. flow rate (※3) ℓ/min.(ANR)	1300	2000	2500
Weight	480 g		



Symbol

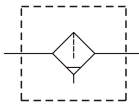

※1. Standard unit contains semi-auto-drain function when operating pressure below 0.05 MPa.

※2. Choose auto-drain FMRF300, the pressure range is 0.15 ~ 1 MPa.

※3. Flow is at pressure P=0.7 MPa with pressure drop ΔP=0.03 MPa.

Order example

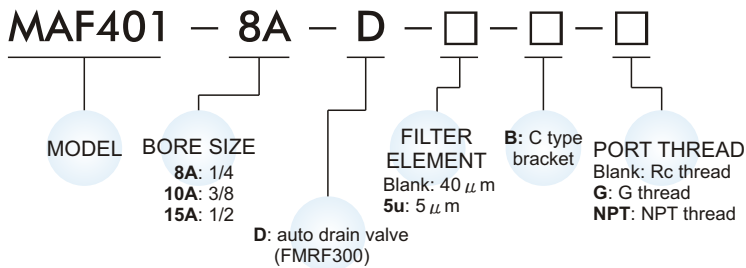

Option accessories

C type bracket

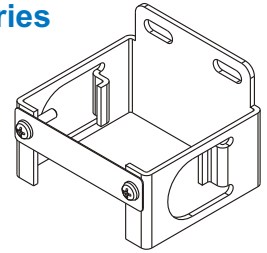

Flow feature

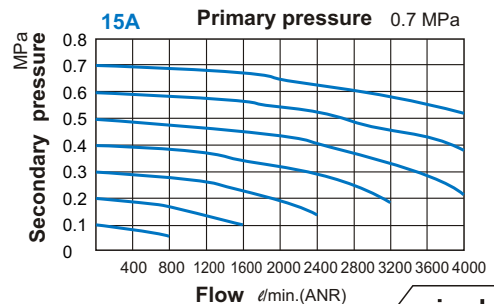
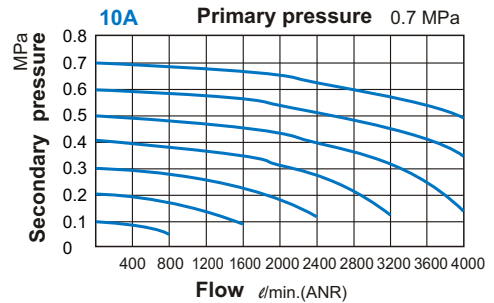
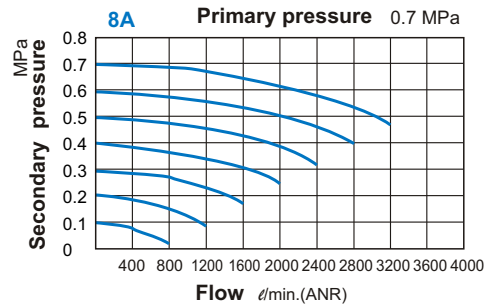
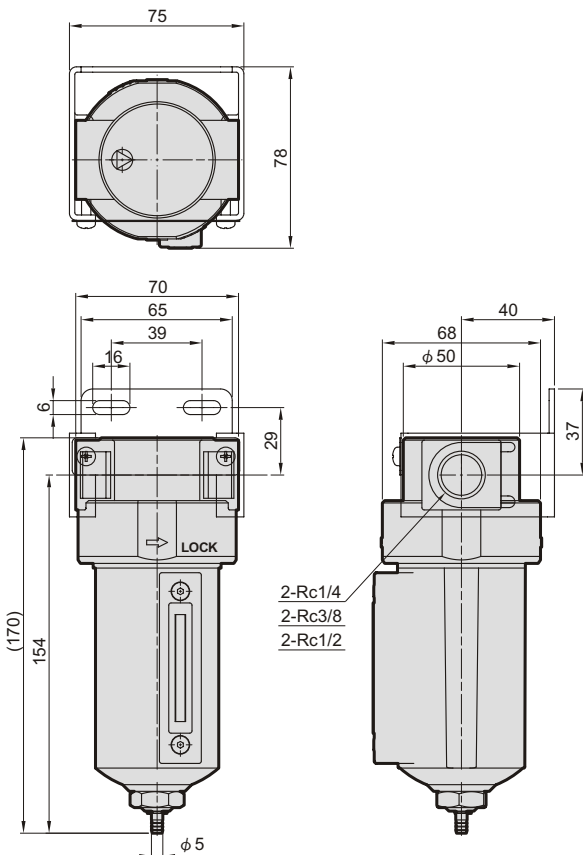

Mindman