

### Order example

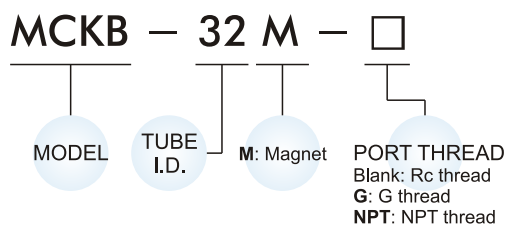

### Features

- Lever type clamp cylinder gives high clamping force.
- Simple mounting of sensors on all four sides of body.
- Hard anodised body gives smooth lines and high corrosion resistance.

### Specification

Model	MCKB	
Acting type	Double acting	
Tube I.D. (mm)	32	
Port size Rc(PT)	Rc1/8	
Operating fluid	Air	
Operating pressure range	0.1~1 MPa	
Test pressure	1.5 MPa	
Ambient temperature	-5~+60°C (No freezing)	
Lubrication	Cylinder	Not required
	Lever	Grease
Available speed range	50~500 mm/sec	
Sensor switch (※)	RCB, RCE, RCE1	

※ RCB, RCE, RCE1 specification, please refer to page V-07, V-09.

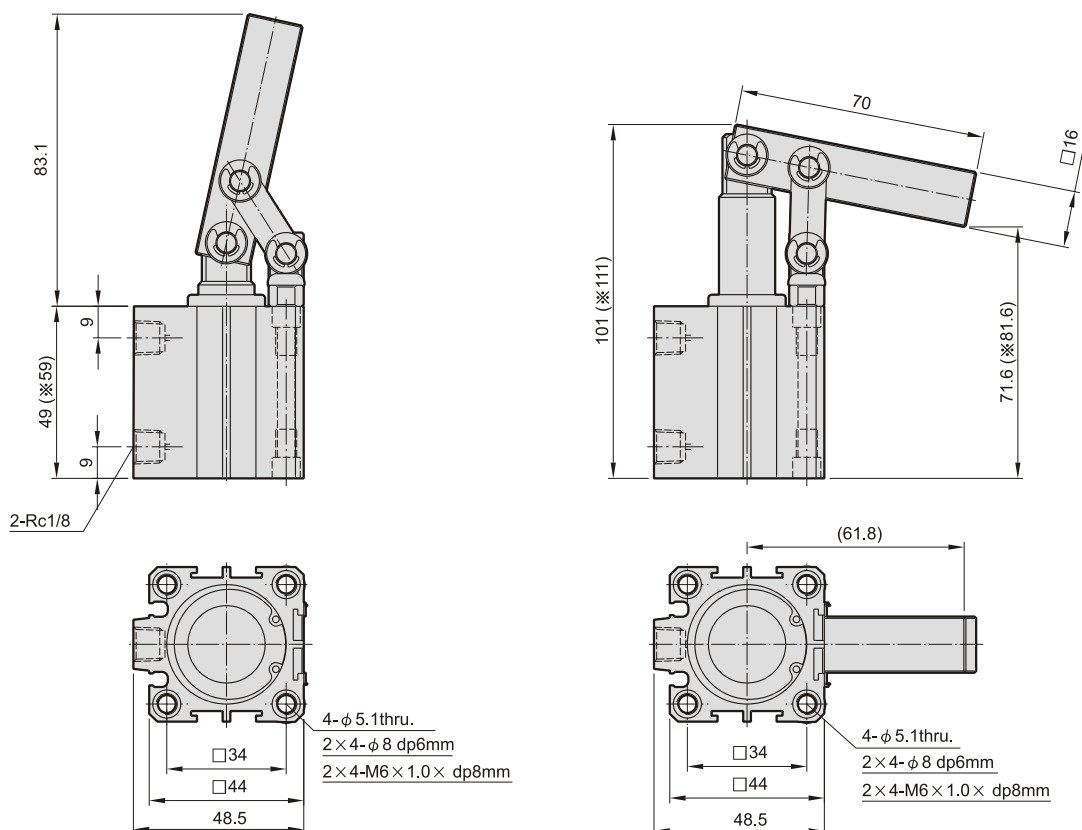

※: Dimension for with magnet

## LEVER CLAMP CYLINDER

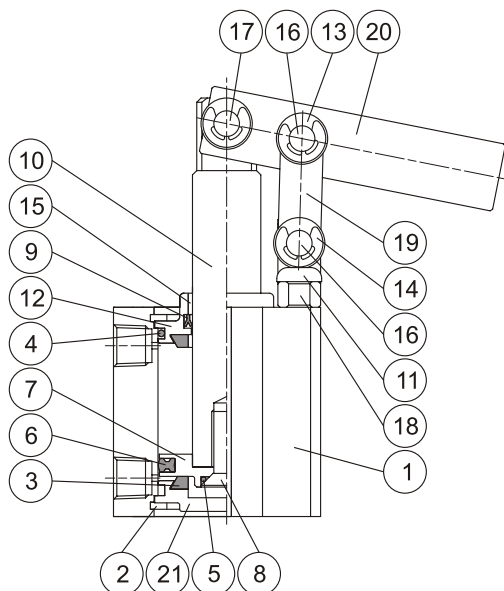

### Material

No.	Part name	Material	Q'y	Repair kits (inclusion)
1	Body	Aluminum alloy	1	
2	Snap ring	Spring steel	2	
3	Cushion	NBR	2	●
4	Cover gasket	NBR	2	●
5	Piston gasket	NBR	1	●
6	Piston packing	NBR	1	●
7	Piston	Aluminum alloy	1	
8	Piston bolt	SCM	1	
9	Rod packing	NBR	1	●
10	Piston rod	Carbon steel	1	
11	Screw	SCM	2	
12	Rod cover	Aluminum alloy	1	
13	Washer	Carbon steel	6	
14	Snap ring	Spring steel	6	
15	Rod bush	Bearing alloy	1	
16	Connecting pin	Stainless steel	2	
17	Lever pin	Stainless steel	1	
18	Holoer	Carbon steel	1	
19	Connecting plate	Carbon steel	2	
20	Lever	Carbon steel	1	
21	Head cover	Aluminum alloy	1	

### Order example of repair kits

Tube I.D.	Repair kits
φ 32	<b>PS-MCKB-32</b>

### Installation of sensor switch

